

Applicator AX11A – Preliminary Datasheet

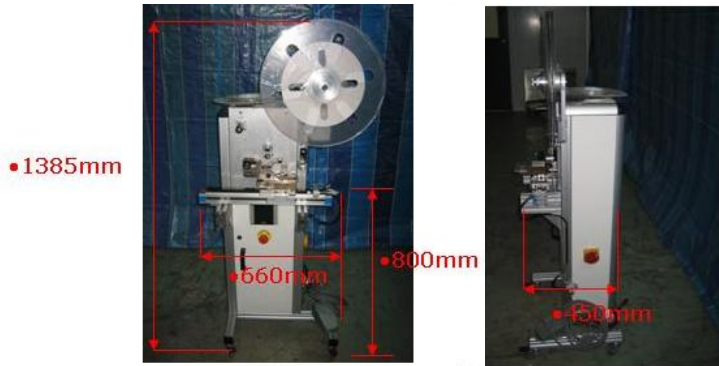

nonClonable™ Label Applicator AX11A

- Automatic label applicator
- Use with Labels SXM12T (reel of 10,000)
- Use with pharmaceutical blister packs (BP)
- Labeled BPs for use with Reader SX21
- Linear barcode label registration
- LAN connectivity for database upload
- BP loading from single line feed
- Single BP output line feed
- Cascadable with feeders and conveyors

Equipment Specifications

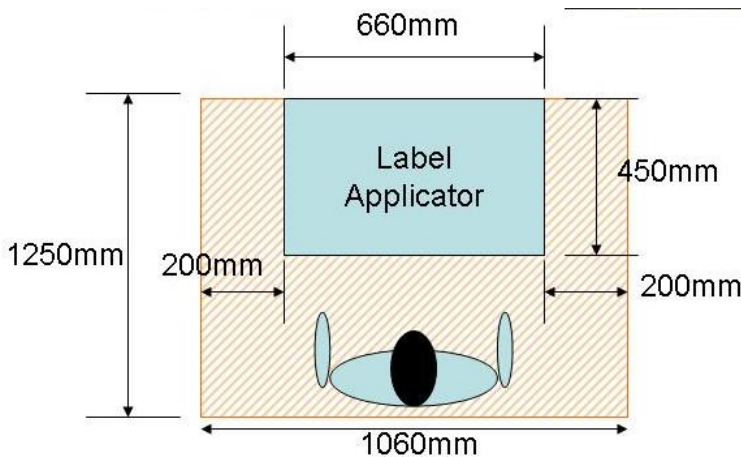

- 1 BPs labeled per second
- Length L = 600 mm
- Width W = 450 mm
- Height H = 1385 mm
- Loading Height HL = 800 mm
- Floor area inc access = 1.25 m x 1.06 m
- CE marked equipment
- 230 V AC / 13 A / 50/60 Hz (single phase)
- TBC dB operating noise level
- TBC kg weight
- Compressed Air (optional) / 6 Bar
- Pallet delivery
- Conveyor accessories as options

Blister Pack Specifications

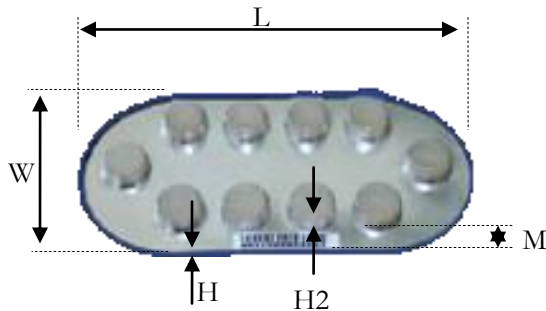

- Handles BPs (L x W x H mm)
- $40 < L < 150$
- $30 < W < 90$
- $0.1 < H < 0.7$
- $0.1 < H2$ (Pocket height) < 6
- $0.6 < M$
- Applied to polymer side
- Straight edge deformation $< 200 \mu\text{m}$