

Robust Data Matrix Labels

Part numbers to be confirmed

- Anodized aluminium substrate
- Pre-assigned laser scribed 14 x 14 Data Matrix code
- 6 mm x 6 mm square
- 150 micrometer thick
- Black with white coding
- Alternative colours on request

Applications

- Equipment leasing industry
- Construction industry

Supply

- Pre-loaded onto database
- Minimum order 1,000 tags
- Provided loose in a box

Uses

- Asset tracking / inventory management using a standard 2D Barcode scanner
- Centralised data management using Bilcare Technologies' software system
- Asset information sharing between lessor and leasee
- Inventory management for audits and compliance

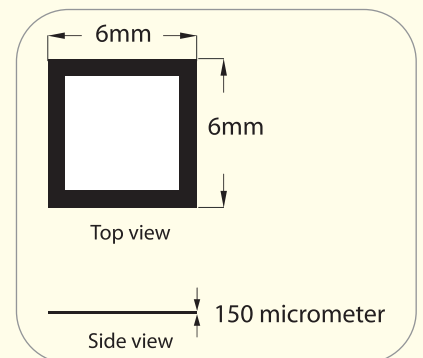

Bilcare
Research